



Heritage & Innovation in Textiles



CROCKTEC AUTO

Colour fastness testing through rubbing (crocking)

Elastocon®

Tvinnargatan 25 • SE-507 30 Brämhult
Tfn: +46 33 323 39 00 • info@elastocon.se
www.elastocon.se

Colour fastness to Crocking is a test that even the most basic of quality standards will require.



FORM

Radical redesign for a dramatic reduction of desktop footprint and unit weight.

Two stage sample clamping system ensuring automated pin location and allowing technician to apply fabric tension.

FUNCTION

- Roaches Orbis touchscreen controller.
- Removable load weight to allow contamination free placement of crocking cloth.
- The Roaches floating 9N load weight allows a constant pressure for different thicknesses and textures of test substrate.
- Constant internal monitoring of the motor, ensuring accurate stroke speed.
- Unique method for stroke length check.

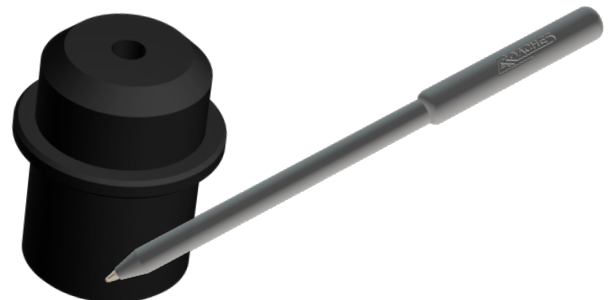

Stroke Length Insert & Roaches Verification Pen



DIMENSIONS & WEIGHTS

Model	Height (H)	Width (W)	Depth (D)	Weight
Crocktec Auto	232 mm	237 mm	386 mm	8 kg

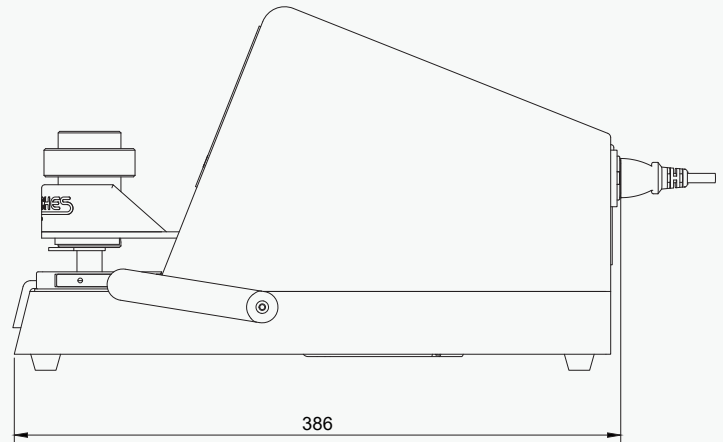
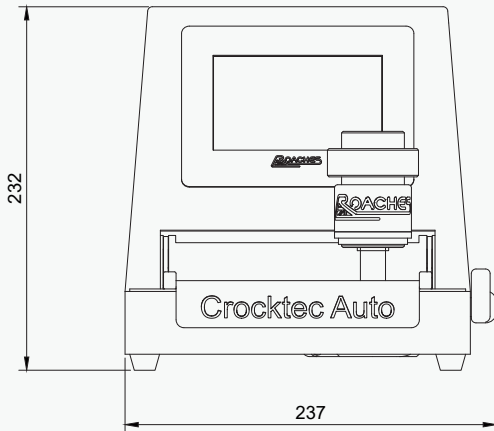

SPECIFICATIONS

Voltage	Frequency	Phases	Amp	Wattage	Air Supply	Water Supply
110V to 230V	50/60Hz	One (1)	0.5A	50W	N/A	Not Required

STANDARDS

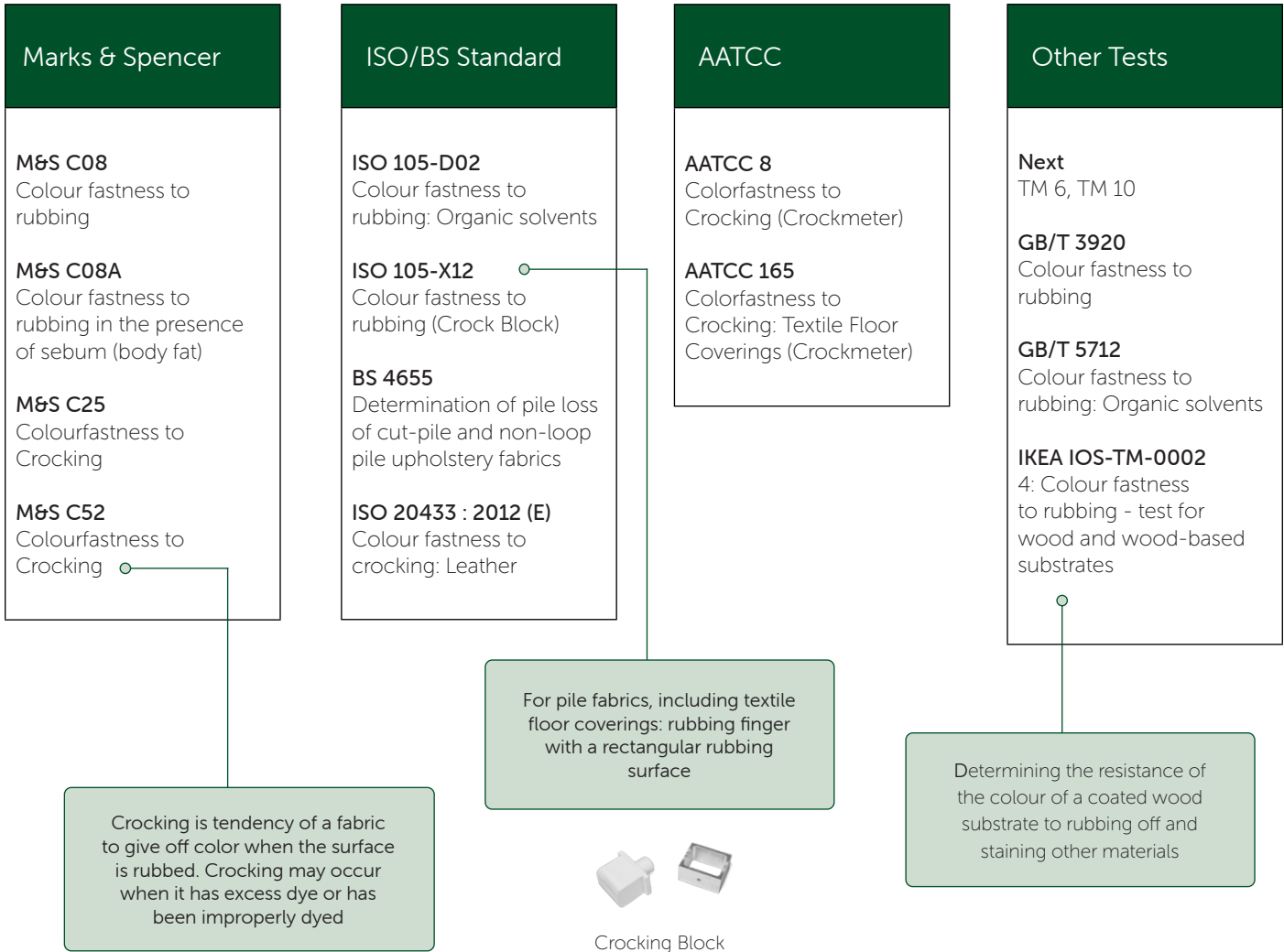

Roaches machines meet specifications set by leading retailers such as:



TEST MATERIALS

Order Code	Description
2000-0001	ISO Grey Scale for Change in Colour (ISO 105 A02)
2000-0002	ISO Grey Scale for Assessing Staining (ISO 105 A02)
2000-0003	AATCC Grey Scale for Change in Color (AATCC EP1)
2000-0004	AATCC Grey Scale for Assessing Staining (AATCC EP2)
2000-2001	Cotton Lawn 5cm x 5cm (Crimped Edges) - Pack of 500
2000-2002	Cotton Lawn 5cm x 5cm (Straight Edges) - Pack of 500
2000-2003	Cotton Lawn (Wide Width) - Per Metre
2000-2004	Cotton Lawn (Wide Width) - 5 Metre Pack
2000-2005	Cotton Lawn 10cm x 20cm (Crimped Edges) - Pack of 50
2000-2006	Roaches Crockmeter 16mm Rubbing Finger
2000-2007	Roaches Crockmeter 16mm Finger Spring Clip
2000-2008	Roaches Crocking Block (ISO 105 X12 & AATCC 165)



☎ +44 (0)1924 420083 ✉ sales@roaches.co.uk 🌐 www.roaches.co.uk

Unit 11 Springwell 27, Dark Lane, Birstall, West Yorkshire, England, WF17 9LN